

Wet Chemistry: Coatings Based on Inorganic-Organic Polymers

K.-H. Haas, S. Amberg-Schwab, K. Rose and G. Schottner,
Fraunhofer-Institut für Silicatiforschung, Germany

Key Words: Permeation barrier coatings
Hydrophilic/Hydrophobic coatings

Polymer substrates
Abrasion resistant coatings

ABSTRACT

Sol-gel based processing of hybrid polymers (ORMOCER®s) with inorganic and organic structural units is used for functionalized coatings on a variety of substrates (ceramics, metals, polymers etc.). At temperatures below 150°C the formation of both inorganic and organic network structures is possible.

This makes these hybrid polymers the material of choice for hard-elastic layers e.g. on polymers. Functional organic groups bound to the inorganic network are used to modify surface properties. These hybrid lacquers can be processed by all conventional coating techniques (dipping, spraying, spin on etc.) and cured by thermal or radiation energy.

These hybrid coatings are useful for:

- abrasion resistance,
- barrier layers,
- decorative layers,
- corrosion resistance,
- antisoiling, antifogging, antistatic and antireflective applications.

Some applications are presented. Economical and environmental issues of sol-gel-processing are addressed. The combination of wet-chemical processing with vapor based coating technologies leads to new high-performance coatings e.g. for barrier applications.

INTRODUCTION

Wet-chemical based coating techniques are standard techniques for a wide variety of surface refinement processes. The materials classically used for these applications are typically lacquers based on organic polymers. In the last 15 years new materials have been developed which can also be processed as lacquer systems. One of these new materials are hybrid inorganic-organic polymer systems like ORMOCER®s. They combine some of the properties of polymers (low to medium

temperature processing, good toughness) with typical properties of inorganic materials (glasses) like hardness and chemical/thermal stability. Figure 1 shows the potential combinations of materials and properties for ORMOCER®s.

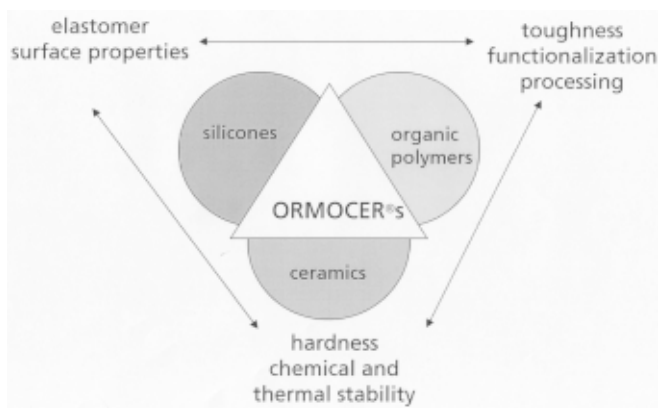

Figure 1. ORMOCER®s: relationship with ceramics (glass)/silicones/organic polymers and combinations of properties.

Due to the possibilities of determining the molecular structures and the properties connected to them by choosing the proper structural elements (see Figure 2) a wide field of applications is accessible.

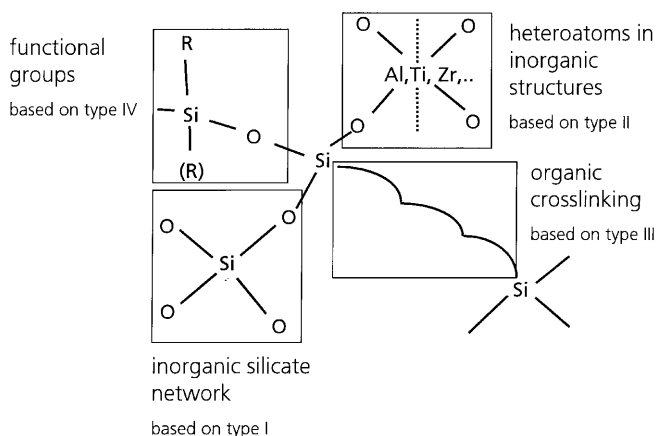

Figure 2. ORMOCER® structural elements

Some important examples for the preparation and application of ORMOCER[®]s by liquid phase processing for coatings are presented. An additional possibility is the combination of wet-chemical processing of ORMOCER[®]s with vapor phase technologies for forming inorganic thin films. This is especially useful for barrier applications.

SYNTHESIS OF ORMOCER[®]S AS COATING MATERIALS

The reaction scheme for the synthesis of ORMOCER[®]s is based on sol-gel processing [1]. Sol-gel processing is useful for the solvent based processing of precursors for inorganic as well as inorganic-organic (ORMOCER[®]) materials. For the preparation of inorganic oxide materials like glasses and ceramics, metal alkoxides are used. The monomers for ORMOCER[®] synthesis are usually bifunctional (type III and IV, see Figure 3).

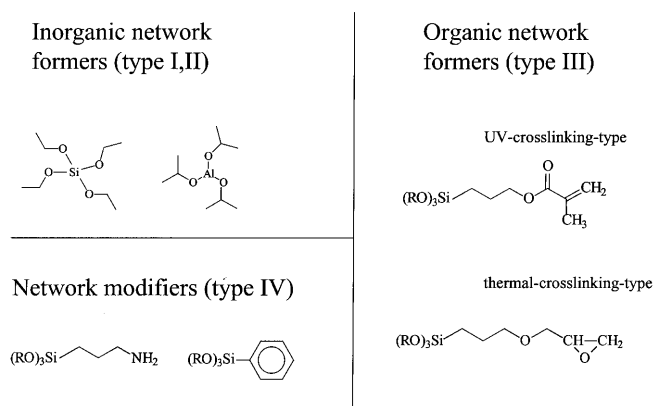
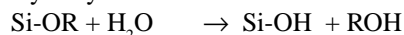

Figure 3. Examples of monomers used for the preparation of ORMOCER[®]s

The inorganic network is mainly based on Si-O-Si-bonds using organically modified Si-Alkoxides $R_xSi(OR)_y$ as starting compounds. Hydrolysis and condensation reactions according to

Hydrolysis:



Polycondensation:

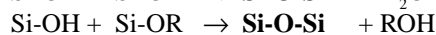
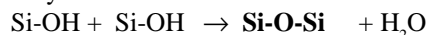

are started and controlled by the addition of water and catalyst to an alcoholic solution of the precursors. A molecularly disperse solution of organically modified oligomers is formed and called the sol (see Figure 4).

The use of non-modified metal alkoxides of Si, Ti, Zr, Al etc. (type I, II) leads to the incorporation of heteroelements in the

inorganic network or to an increase in inorganic Si-O-Si crosslinking in the case of Si.

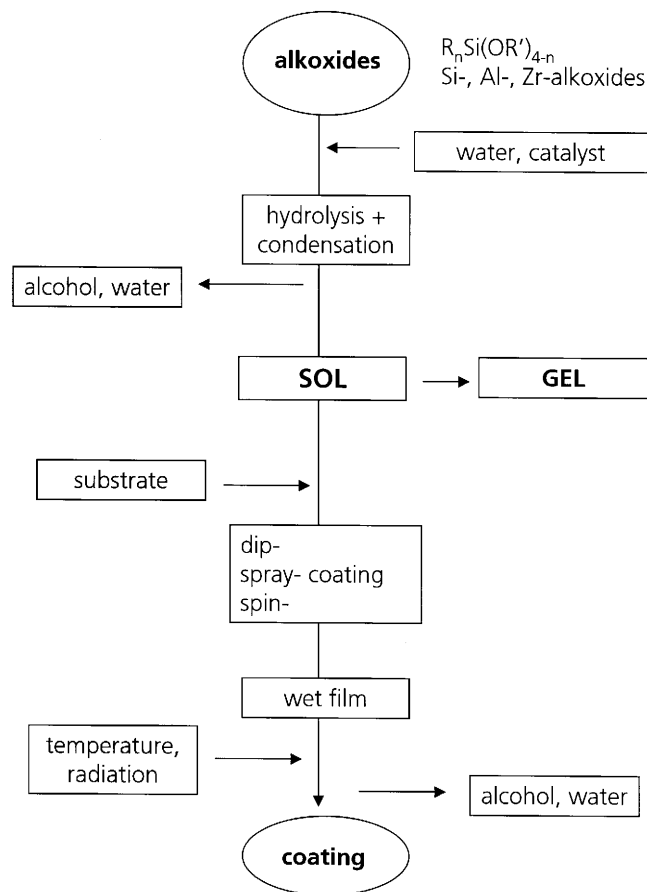

Figure 4. Sol-gel processing scheme for ORMOCER[®] coatings.

The addition of heterometal alkoxides increases the stiffness of the material and is also useful for controlling refractive indices and porosity of ORMOCER[®]s.

The sol is applied on a substrate and the wet film is crosslinked thermally or by using UV/IR-radiation. Reactive groups (R_x) linked through covalent chemical bonds to the inorganic network react in the wet film through organic crosslinking reactions. Two important examples for alkoxides used for organic crosslinking reactions are shown in Figure 3. Organically modified Si-alkoxides which do not carry reactive functional groups (type IV, see Figure 3) led to a modification of the inorganic network (e.g. polarity control).

The control of properties of the materials for special applications is mainly determined through the use of these four structural elements and the conditions of forming inorganic and organic networks. Materials with high inorganic contents are stiff but brittle. Elasticity is realized by using inorganic structures with a proper amount of organic crosslinking.

Sol-gel processing of ORMOCER[®]s cannot only be used for the preparation of coatings, but also for bulk materials and composites, where the organic crosslinking plays an important role (using e.g. multifunctional acrylic Si-alkoxide systems [2]).

Another example for the use of ORMOCER[®]s is micro systems technology. Thin films with very good dielectric properties, good adhesion to various substrates, low optical losses and the patternability with negative resist behaviour [3] can be realized. ORMOCER[®]s are also good passivation layers for electronic components [4].

This contribution will focus on functional ORMOCER[®] coatings for abrasion resistance, anti-soiling, anti-static properties and barrier functions. Information about the use of ORMOCER[®]s as corrosion protecting layers [5], antireflective coatings [6], decorative layers on glass [7] or gas-sensitive layers [8] can be found elsewhere.

APPLICATION EXAMPLES OF ORMOCER[®] COATINGS

Coating and Curing Techniques

One very important feature of ORMOCER[®]s is their good adhesion to a variety of substrates (polymers, metals, oxidic surfaces of glasses and ceramics). The basic adhesion mechanism on metals and oxidic surfaces is the reaction of Si-OH groups of the ORMOCER[®] sol with surface OH-groups of the substrates forming a covalent bond to the surface. Interaction with polar polymer surfaces is often possible through functional organic groups of the ORMOCER[®]. Substrate pretreatment by corona discharge or by special primer solution is necessary in some cases in order to guarantee long-term adhesion.

As coating techniques e.g. dip-coating, spray-coating, spin-coating etc. is possible as in the case of pure organic coating materials. ORMOCER[®] wet films are cured through heating (typically 1 h at 130 °C depending on the system) or UV-irradiation (for substrates with lower thermal resistivity). Typical ORMOCER[®] film thickness is in the range of 4 - 15 µm.

Abrasion Resistant Coatings on Polymers

The first successful application of ORMOCER[®]s were scratch/abrasion resistant coatings for transparent polymer substrates (CR39-based lenses [9]). In the meantime ORMOCER[®] systems (UV- or thermal curing) for various polymer substrates have been developed [10,11] (See Fig 5). The taber-abraser test, which is an indication of resistance to abrasion, shows that a tremendous increase in mechanical stability of polymer surfaces can be achieved with ORMOCER[®] coatings.

The mechanical durability of ORMOCER[®] coatings is their basic advantage and the combination with additional functions can thus lead to other interesting applications.

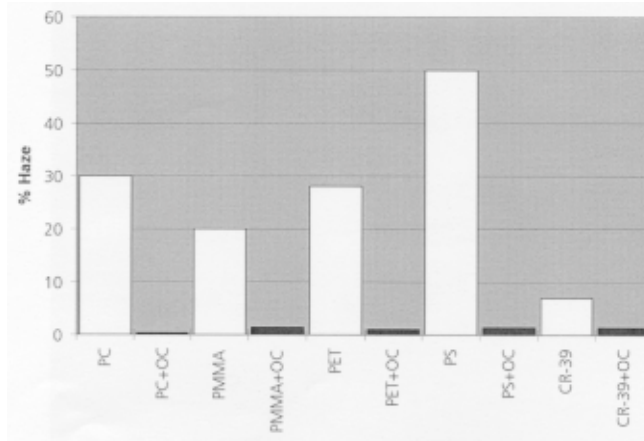

Figure 5. Taber-abraser values of ORMOCER[®]s (+OC) on various polymer substrates (ASTM D1044; 100 cycles) compared with values for the uncoated polymers (PC, PMMA, PET, PS, CR39).

Anti-Soiling and Antistatic Properties

The introduction of functionalized alkoxides (type IV) into ORMOCER[®] systems modifies the coating surfaces. Hydrophilic/-phobic and/or oleophilic/-phobic properties can be achieved by the incorporation of appropriate functional groups [12]. The wetting behaviour of a conventional spray lacquer on an unmodified and fluorosilane modified ORMOCER[®] coating on glass is shown in Figure 6. Due to the oleophobic nature of these surfaces antigraffiti-behaviour with good mechanical abrasion stability on transparent substrates can be achieved.

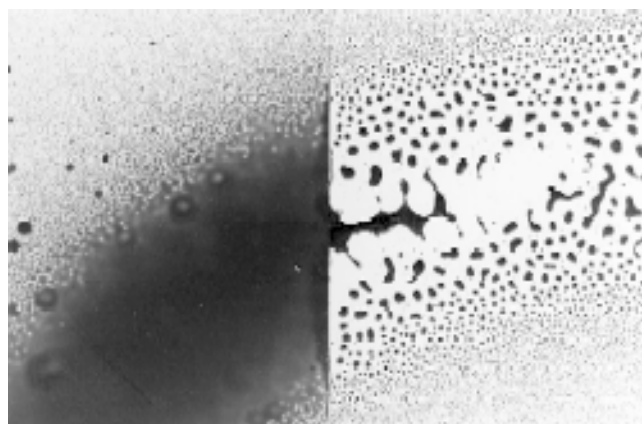

Figure 6. Antigraffiti-behaviour of fluorosilane modified ORMOCER[®]s on glass substrate (left side uncoated)

Another modification of ORMOCER[®] surfaces leads to anti-static coatings for polymer surfaces. Abrasion resistant ORMOCER[®] coatings are prepared by introducing polar functions (amino-functionalized Si-alkoxides, type IV) e.g. on PC substrates with a surface resistivity of 10^8 - 10^{10} Ω (compared

to 10^{15} - $10^{16} \Omega$ for unmodified ORMOCER® surfaces). The anti-statically active component is fixed to the inorganic network which gives improved behaviour since no leaching of components can occur.

ORMOCER® Barrier Layers

The dense inorganic network of ORMOCER®s combined with organic crosslinking and the possibility to control the polarity of the matrix, makes them useful as barrier layers for gases, vapors and ions. Reduced water permeation was first investigated for the passivation (encapsulation) of electronic components (thin film capacitors [4]). The lifetime of thin film capacitors by the application of thin ORMOCER® coatings could be extended to 60 days in wet climate, compared with 30 days by conventional costly and bulky epoxy encapsulation.

The application as transparent barrier layers for food packaging was tested on polymers like PET, OPP, BOPP (mono- or biaxially oriented polypropylene) conventionally used for food packaging. Permeants in food packaging applications are water vapor, oxygen and flavours. Uncoated BOPP has distinct permeation rates for various selected flavours (see Figure 7; details about measurements see [13]).

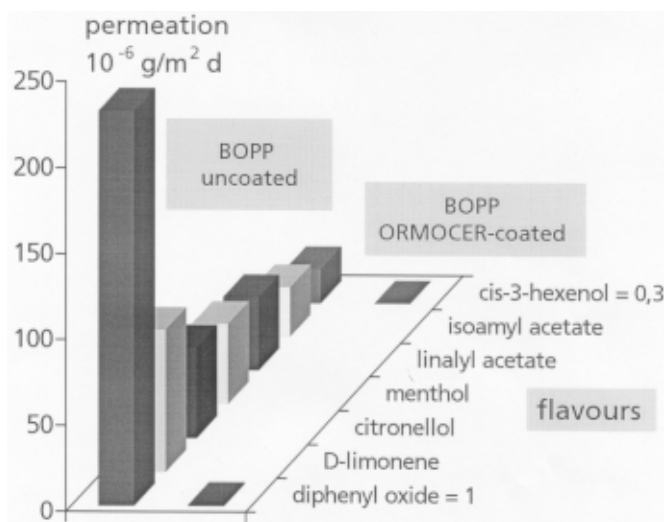

Figure 7. ORMOCER® coating on BOPP and barrier effects for various flavours.

The coating of BOPP with ORMOCER® systems (thermal curing) reduces the permeation of 5 out of 7 flavours to values below the detection limit of the experiment [14]. Only 2 flavours could barely be detected after 3 months permeation with very low permeation rates. This shows that ORMOCER®s can be used as effective barriers for molecular organic compounds.

For most food packaging materials a combination of barrier properties for water, oxygen and flavours is needed. This is

achieved by the combination of various polymer/metal films, as barrier for either polar or unpolar components [15].

For example Al-coated PET is used as food packaging material showing permeability for water vapor and oxygen in the high barrier region ($<1 \text{ g/m}^2\text{-d}$ for water vapor and $< 1\text{cm}^3/\text{m}^2\text{-d}\cdot 10^5 \text{ Pa}$ for oxygen) [15]. For Al-coated BOPP, the oxygen permeability is often not sufficient (> 20). For transparent coatings SiO_x -coated PET or BOPP is used. SiO_x (x ranging from 1.5-1.8 [15]) shows very good barrier properties for oxygen and water, but the adhesion to the polymer films and the mechanical properties are often not sufficient as top coat. For practical applications SiO_x -coated polymer films are laminated in order to protect the SiO_x -layer. Here we present the combined use of ORMOCER®s and SiO_x coatings in order to achieve high barrier films.

The use of ORMOCER®s as top layers on SiO_x -coated OPP [16] and their influence on the oxygen permeability is shown in Figure 8.

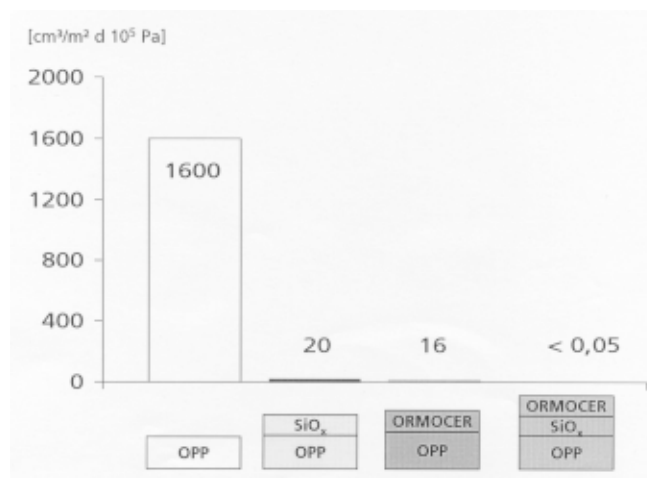

Figure 8. Oxygen permeability on various coated OPP films.

A thermally cured ORMOCER® reduces the permeability of OPP from more than 1500 to values around 15. SiO_x coated OPP shows slightly higher permeability. The combination of SiO_x and ORMOCER®, is very efficient and the high barrier region can be reached with permeabilities below the detection limit ($< 0,05$). The water vapor permeability of this combination is around 0.1, thus reducing the already good values of pure OPP (=1). Also in case of PET the combination of SiO_x and ORMOCER® is very effective (Oxygen permeability of ORMOCER®s on PET: 20-25, SiO_x coated PET: around 5). The combination of both resulted in permeation values in the high barrier region ($< 0,05$).

Since the calculated permeation value of e.g. oxygen for the combination of SiO_x and ORMOCER® films is higher (around

1) than the values measured in the permeation experiment (<0,05) some synergistic effect can be assumed. Our explanation of this behaviour of SiO_x-ORMOCER® coatings is as follows: The reaction of the ORMOCER® lacquer with remaining Si-OH groups of SiO_x leads to a good adhesion to SiO_x thereby also reducing the remaining microporosity of SiO_x.

The use of ORMOCER®s as laminating agents for SiO_x-coated PET and the mechanical properties of various ORMOCER® containing PET or OPP laminates is described in more detail in [14, 16].

Economic and Environmental Aspects

The application of ORMOCER®s as wet chemical based coatings on an industrial scale has to be competitive in price and technology. Therefore economic aspects play an important role. As this is the case with other wet chemical based organic coatings the investment costs are low compared to vapor-based coating technologies since no vacuum step is needed in the preparation of the coating. ORMOCER® coatings are in the price regime of 0,5-1,5 US \$ per m² coated surface (average coating thickness assumed 5 µm). Here also not the price of the coating lacquer is decisive but the economy of the coating technology (over spray etc).

ORMOCER® coating lacquers are usually water/alcohol based (solvent exchange possible). In some cases also water-borne systems (less than 10 % organic solvent) can be used. ORMOCER® powder coatings are so far only available in special cases.

CONCLUSIONS

ORMOCER®s as molecular composite materials are processed by liquid phase reactions and have promising applications as transparent coatings. Beside their basic abrasion resistance, anti-soiling and anti-static-behaviour can be generated both with long-term stability and mechanical resistance. Barrier applications with ORMOCER®s are also promising developments. Especially the combination of ORMOCER®s with "vapor borne" inorganic coatings like SiO_x show excellent barrier values combined with good mechanical properties and processability.

ACKNOWLEDGEMENTS

The contribution of all people from the Fraunhofer-Institut für Silicatforschung (ISC), the Fraunhofer-Institut für Verfahrenstechnik und Verpackung (IVV) and the Fraunhofer-Institut für Elektronenstrahl- und Plasmatechnik (FEP) which are engaged in ORMOCER® coatings research is greatly acknowledged. We are also grateful for the support by various public funds and industrial companies.

ORMOCER®: Trademark of Fraunhofer-Gesellschaft zur Förderung der angewandten Forschung e.V. in München

REFERENCES

1. C. J. Brinker and G. W. Scherer, Sol-Gel-Science, Academic Press San Diego 1990
2. H. Wolter, W. Glaubitt and K. Rose, "Multifunctional (Meth)Acrylate Alkoxysilanes - A New Type of Reactive Compounds," in M.J. Hampden-Smith, W.G. Klemperer and C.J. Brinker (ed.), Better Ceramics through Chemistry V, Mat. Res. Soc. Symp. Proc. Vol. 271 (1992) 719-724
3. M. Popall et al, "ORMOCER®s - New Photo-Patternable Dielectric and Optical Materials for MCM-Packaging," Proceedings 48th COMPONENTS & TECHNOLOGY CONFERENCE, Seattle, Washington USA, 8 (1998) 1018-1025 (CD-ROM-Version) Ed. Institute of Electrical and Electronics Engineers, Inc. 1998 IEEE-Catalog Nr. 98CH36206
4. M. Popall, J. Kappel, M. Pilz and J. Schulz, "A new inorganic-organic polymer for passivation of thin film capacitors," J. of Sol-Gel-Science and Technology, 2 (1994) 157-160
5. K. Greiwe, "Korrosionsbeständige Schutzbeschichtung für Messingoberflächen," farbe + lack (1991) 968 - 971
6. J. Kappel and K. Rose, "Manufacture of antireflective coatings by replication of submicrometer patterns in inorganic-organic hybrid polymers," Proceedings of 18th International Congress on Glass San Francisco 1998 (CD-Version) Ed. Manoj K. Choudhary, Norman T. Huff, Charles H. Drummond III, American Chemical Society CD San Francisco, 1998
7. G. Schottner, J. Kron and K.-J. Deichmann, "Industrial application of hybrid sol-gel coatings for the decoration of crystal glassware," J. Sol-Gel Sci. Tech. 1/2 (1998) 183-187
8. V. Matejec, K. Rose, M. Hayer, M. Pospisilova and M. Ghomat, "Development of organically modified polysiloxanes for coating optical fibers and their sensitivity to gases and solvents," Sensors and Actuators B 38 - 39 (1997) 438 - 442
9. H. Schmidt, B. Seiferling, G. Philipp and K.-J. Deichmann, "Development of organic-inorganic hard coatings by the sol-gel process," in J.D. Mackenzie and D.R. Ulrich (eds.), Ultrastructure processing of Advanced Ceramics, John Wiley & Sons, New York, 1988, 651-660

-
10. S. Amberg-Schwab, E. Arpac, W. Glaubitt, K. Rose, G. Schottner and U. Schubert, "Protective Coatings for Organic Polymers by Sol-Gel Techniques," in P. Vincenzini (ed.), *High Performance Ceramic Films and Coatings, Materials Science Monographs*, Vol. 67, Elsevier Science Publishers B.V. (1991) 203-210
 11. K.-H. Haas, S. Amberg-Schwab, K. Rose and G. Schottner, "Functionalized coatings based on inorganic-organic polymers (ORMOCER[®]s) and their combination with vapor deposited inorganic thin films," in *Surface and Coatings Technology* 111 (1999) 72-79
 12. J. Kron, S. Amberg-Schwab and G. Schottner, "Functional coatings on glass using ORMOCER[®]s-systems," in *J. of Sol-Gel Science and Technology* 2 (1994) 189-192
 13. R. Franz, "Permeation of volatile organic compounds across polymer films Part 1: Development of a sensitive test method suitable for high-barrier packaging films at very low permeant vapor pressures" *Packag. Technol. Sci.* 6 (1993) 91-102
 14. S. Amberg-Schwab, M. Hoffmann, H. Bader, M. Gessler, "Inorganic-organic hybrid polymers with barrier properties for water vapour, oxygen and flavours" in *J. Sol-Gel Sci. Tech.* 1/2 (1998) 141-146
 15. J. Nentwig, "Kunststoff-Folien", Carl Hanser Verlag München, Wien 1994
 16. M. Gessler, H. Bader, M. Hoffmann, S. Amberg-Schwab, "Transparente, flexible Hochbarrierefolien durch Kombination von aufgedampften, anorganischen Schichten mit anorganisch-organischen Hybridpolymeren" in *Coating* 10 (1997) 358-361